

Product discontinued!
Replacement requirement only on request.
Replaced by series TP1.

Transducer up to 4500 mm touchless absolute

Series TLM
with CANopen
interface

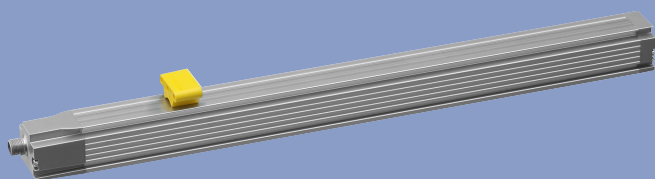

Special features

- absolute transducer, no slide arm required
- NOVOSTRICTIVE[®], touchless magnetostrictive measuring process
- non-contacting guiding with floating position marker
- unlimited mechanical life
- no velocity limit for position marker
- outstanding linearity performance up to 30 µm
- resolution up to 0.001 mm regardless of stroke length
- low temperature coefficient <20 ppm/K
- insensitive to shock and vibration
- optionally cable or plug connection
- protection class IP67 / IP68
- CANopen compatible CiA standard DS-301 Rev. 4.02 and standard device profile DSP-406 Rev. 3.1
- encoder class C1
- up to 2 position markers adaptable
- speed, cams programmable
- address adjustment via LSS DSP 305 V1.1.2 or SDO object 0x2000
- autobaud function

Transducers employing the NOVOSTRICTIVE[®] touchless magnetostrictive measuring process for direct, precise and absolute measurement of linear position in control, positioning and measuring technology.

The measurement is accomplished using a passive position marker which can be moved as a free-floating or guided element.

Side coupling of the position marker reduces the installation envelope size, prevents the pump effect of slide arms and permits stroke lengths up to 4500 mm. The non-contact coupling version makes installation even simpler, and the wear-free operation means unlimited mechanical life expectancy and unlimited traverse speed of the position marker.

The temperature coefficient of the transducer is extremely low thanks to the measuring principle, design and selected materials.

The high mechanical ruggedness of the transducer combined with the underlying measuring technique mean that the system is highly resistant to shock and vibration. The active sensing element is encased in an aluminum housing rated to IP 67. This makes the transducer resistant to contamination, dust, moisture and oils.

Mounting is accomplished using clamps that allow precise mechanical adjustment.

A sophisticated ASIC in the transducer provides for standard absolute output signals. The CAN protocol of these transducers is compatible with CiA Standard DS-301 Rev. 4.02 and standard device profile DSP-406 Rev. 3.1 according to encoder class C1. The position and velocity of up to 2 position markers are transmitted on the bus using "Process Data Objects" (PDO's). Additionally, according to standard freely programmable cams are available

to signalize the passing of certain positions.

Via CAN Interface the node-ID, baud rate, transmission mode, transmission cycle time, slope and travel direction and other parameters can be largely varied. The parameters for configuration of the sensor are sent by the CAN controller in "Service Data Objects" (SDO's). Node ID and data rate are varied either in Layer Setting Service (LSS; nach DSP 305 V1.1.2) or using SDO Object 0x2000. They are stored in non-volatile memory.

As a special feature, the sensor offers the Autobaud function: The Sensor is able to detect the bit rate of the CAN network by "listening" to the communication of existing bus members and to adjust his bit rate accordingly.

Additional interfaces see separate data sheets.

Description

Housing	Anodized aluminium with metal end cap
Mounting	Compression clamps, longitudinally adjustable
Position marker	Floating marker, plastic Guided marker, ball coupling
Measuring technique	NOVOSTRICTIVE [®] , touchless magnetostrictive
Electrical connection	5-pin round connector, shielded, M12x1 6-pin round connector, shielded, IEC130-9
Electronics	Integrated SMD with ASIC Cable shield connected to housing

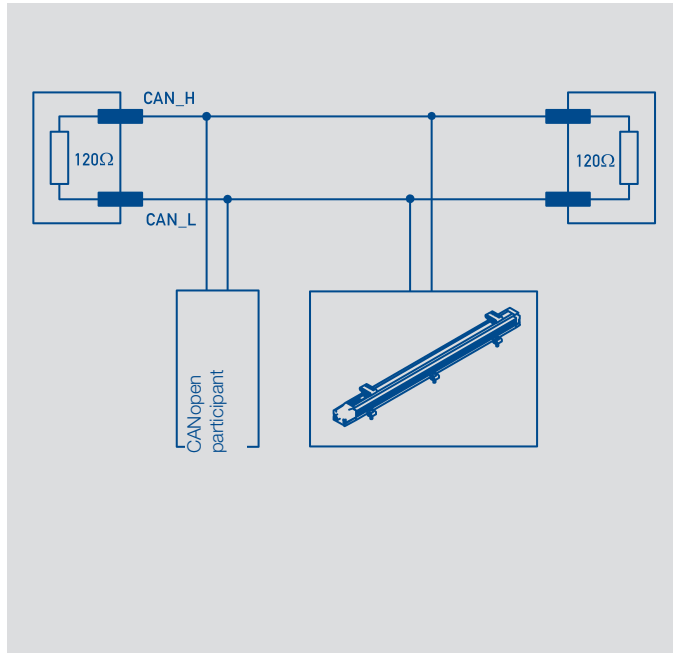
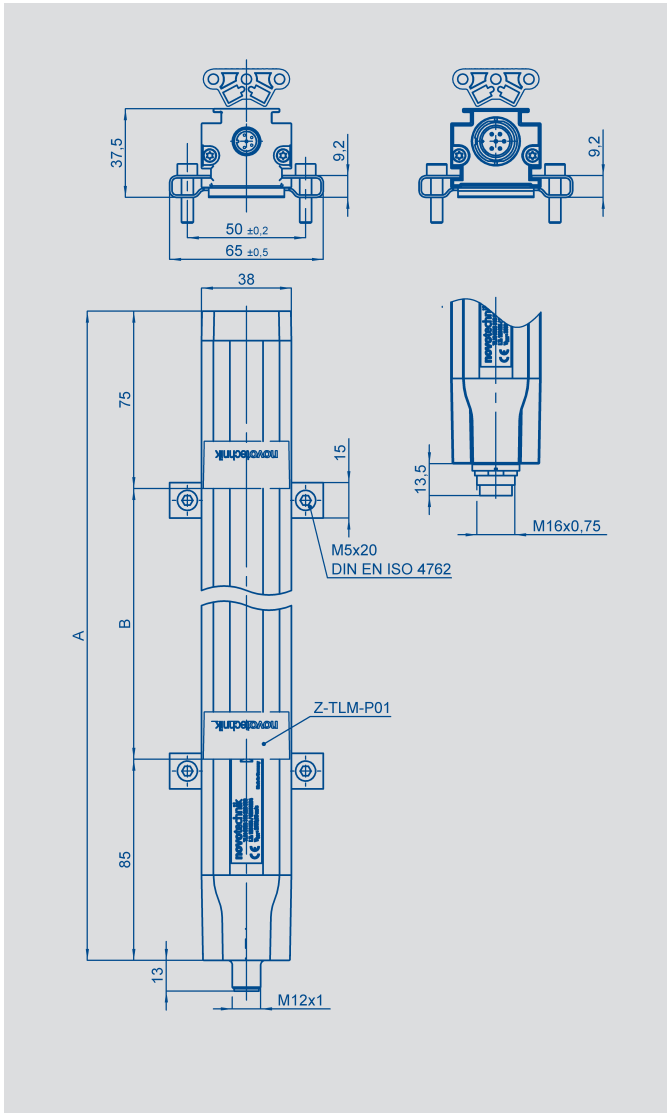

PIN	Connector Pin Code 105	Connector Pin Code 106
PIN 1	CAN_L	(CAN_SHLD)
PIN 2	CAN_H	CAN_V+
PIN 3	(CAN_SHLD)	CAN_GND
PIN 4	-	CAN_H
PIN 5	CAN_V+	CAN_L
PIN 6	CAN_GND	n/a

Signal	Description
CAN_L	CAN_L bus line (dominant low)
CAN_H	CAN_H bus line (dominant high)
(CAN_SHLD)	Optional CAN shield (internally connected to CAN_GND)
CAN_V+	+24 VDC
CAN_GND	Ground 0 VDC

Type designations	TLM xxxx xxx 6xx xxx CANopen interface	
Electrical Data		
Defined electrical range (dimension B)	from 0050 to 4500	mm
Absolute linearity	$\leq \pm 30 \mu\text{m}$	
Output signal	digital (CAN bus)	
Resolution	≤ 1 digit	
Reproducibility	≤ 2 digits	
Hysteresis	≤ 1 digit	
Supply voltage	$24 \pm 20 \%$ reverse polarity protected	VDC
Supply voltage ripple	max. 10 %	Vpp
Current draw	≤ 100 typical	mA
Output up date rate	≤ 16	kHz
Shielding	connected to housing	
Temperature coefficient	≤ 20	ppm/K
Overvoltage protection	40 (Transzorb protection diodes)	VDC
Revers voltage	yes	
Insulation resistance (500 V, 1 bar, 2 s)	≥ 10	M Ω
Mechanical Data		
Dimensions	see drawing	
Environmental Data		
Operating temperature range	-40...+85	°C
Storage temperature range	-40...+100	°C
Operating humidity range	0...100	%R.H.
Shock per DIN IEC68T2-27	100 (11 ms)	g
Vibration per DIN IEC68T2-6	20 (5...2000 Hz, $A_{\text{max}} = 0,75$ mm)	g
Protection class per DIN 40050 IEC 529	IP67 with fastened connector	
Mechanical data when used with floating position marker		
Traverse speed of position marker	unlimited	ms^{-1}
Traverse acceleration of position marker	unlimited	ms^{-2}
Life	unlimited (mechanical)	movements
Standard defined electr. range (dimension B)	0050 up to 1000 in 50 mm steps, 1000 up to 2000 in 100 mm steps, 2000 up to 4500 in 250 mm steps; other lengths in 10 mm steps on request	
CE-conformity		
Emissions	RF noise field strength EN 55011 Group 1 Class A	
Noise immunity	ESD EN 61000-4-2 Radiated immunity EN 61000-4-3 BURST EN 61000-4-4 Conducted disturbances induced by RF fields EN 61000-4-6	

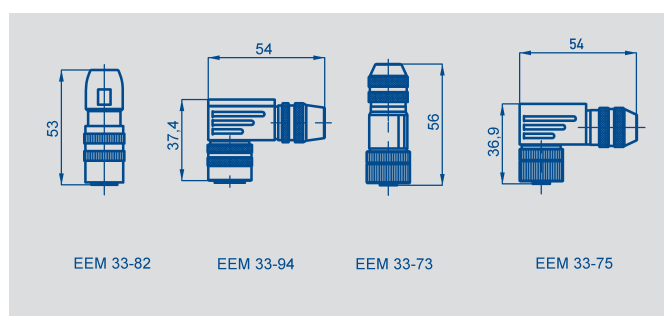
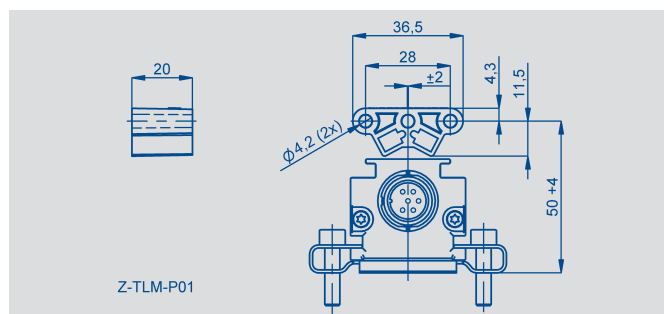

Ordering specifications

Electrical Interface

6: CANopen DS301 V 4.1 DS406 V 3.1

Output signal CANopen interface 6XX

- 1: 1 x pos. resolution 5 µm and 1 x vel. resolution 0.5 mm/s
- 2: 2 x pos. resolution 5 µm
- 5: 2 x resolution 5 µm and 2 x vel. resolution 0.5 mm/s on request

CANopen interface 6XX

- 1: baud rate 1000 kBaud, Default Node-ID 127
- 2: baud rate 800 kBaud, Default Node-ID 127
- 3: baud rate 500 kBaud, Default Node-ID 127
- 4: baud rate 250 kBaud, Default Node-ID 127
- 5: baud rate 125 kBaud, Default Node-ID 127
- 7: baud rate 50 kBaud, Default Node-ID 127
- 8: baud rate 20 kBaud, Default Node-ID 127
- 9: baud rate 10 kBaud, Default Node-ID 127

Electrical connection

- 105: 1 x 6-pin round connector IEC130-9
- 106: 1 x 5-pin round connector M12x1

T L M 0 8 0 0 0 0 1 6 1 4 1 0 6

Series

Defined electr. range
 Several standard lengths
 from 0050 to 4500 mm

Mech. configuration
 001: profile design

Included in delivery

Mounting clamps Z46
 electrically isolating incl. fillister
 head screws

Required accessories

Floating position markers
 Z-TLM-P01, Art.No. 005651,
 Z-TLM-P04, Art.No. 005654;
 Guided position marker
 Z-TLM-P05, Art.No. 005655;
 Other position markers on
 request

Recommended accessories

Connector IEC 130-9,
 EEM 33-82, IP67,
 Art.No. 005639;
 Angled connector IEC130-9,
 EEM 33-94, IP67,
 Art.No. 005648;
 Connector M12x1,
 EEM 33-73, IP67,
 Art.No. 005645;
 Angled connector M12x1,
 EEM 33-75, IP67,
 Art.No. 005646.

Available on request

Other resolutions
 Specific connectors
 Other interface variations
 Start-Stop, SSI, DyMoS,
 Analogue, field bus

Important

Avoid equalizing currents in
 the cable shield caused by
 potential differences. Twisted
 pairs are recommended.