

**NOVOHALL
Rotary Sensor
Non-contacting**

RSA-3200
4 ... 20 mA

Mobile Applications

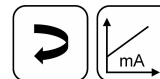

Special Features

- Contactless hall technology
- Electrical range up to 360°
- High protection class IP67 rep. IP69K (housing side)
- Resolution up to 12 bits
- Temperature range -40°C to +105°C
- One and multi-channel versions
- Optimized for use in mobile applications
- For highest EMC requirements such as ISO pulses and interference fields according to ISO 11452 and ECE directive
- Suitable for safety-related applications according to DIN EN ISO 13849
- Suitable for linkage lever mounting
- Other configurations see separate data sheets

Applications

- Mobile working machines (industrial trucks, construction machinery, agricultural and forestry machinery)
- Marine applications

Mobile working machines or truck conveyors place very high demands on the sensor system due to the external application. The very compact angle sensor RSA-3200 offers reliable function under harsh operating conditions.

The sensor is optimized for mobile applications and is certified according to the highest EMC standards such as ISO pulses and interference fields according to ISO 11452.

Available are one and multi-channel versions which are suitable for use in safety-related applications. The stainless steel shaft is designed for assembling of lever arms.

Description

Material	Housing: high grade, temperature resistant plastic PBT-GF with SS inserts Shaft: SS X10CrNiS18-9 1.4305 / AISI 303 Sealing: HNBR 70
Mounting	With 2 screws M4
Fastening torque of mounting	250 ± 50 Ncm
Bearing	Sintered bronze bushing
Sealing	Double O-ring seal, electronics completely encapsulated
Electrical connection	6-pin MQS-connector, code A, tinned contact according to drawing AMP-114-18063-126, Index A1 (Connector: AMP P/N 1-967616-1)

Mechanical Data

Dimensions	See dimension drawing
Mechanical travel	continuous
Permitted shaft load (static)	40 N (axial) / 50 N (radial)
Torque	Typ. 1.5 Ncm Depending on the environmental temperature and standstill time, the necessary force for the initial operating of the shaft may increase
Weight (w/o connection)	approx. 45 g

Ordering Specifications

Ordering Specifications

Preferred types printed in bold

- Delivery time up to 25 pcs. within 10 working days EXW
- Best low-volume pricing

Supply voltage U_b

3: $U_b = 12/24$ VDC

Output signal

2: 4 ... 20 mA

Output characteristic

1: Rising characteristic cw

2: Rising characteristic ccw

3: Crossed outputs, channel 1 rising cw (partly redundant)

4: Crossed outputs, channel 1 rising cw (fully redundant)

Other output characteristics on request

Electrical connection

521: Connector AMP MQS 6-pin, male

R S A - 3 2 0 1 - 6 3 6 - 3 2 1 - 5 2 1

Series

Mechanical version

Output characteristic A (standard)

3201: Standard design

3202: with mounted lever arm Z-RSA-M01

Output characteristic B (180° offset)

3221: Standard design

3222: with mounted lever arm Z-RSA-M01

Measuring range

03: Angle 0° ... 30° min.

...

06, 12, 18, 24, 36

...

36: Angle 0° ... 360° max.

Other angles on request

Number of channels

6: Single-channel version (1x supply voltage U_b , 1x output)

7: Partly redundant version (1x supply voltage U_b , 2x output)

8: Fully redundant version (2x supply voltage U_b , 2x output)

Drawing

CAD data see
www.novotechnik.de/en/download/cad-data/

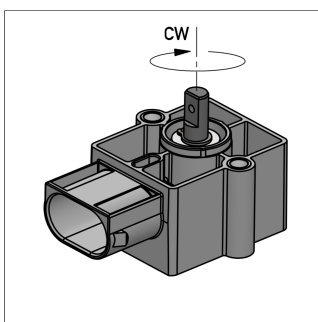
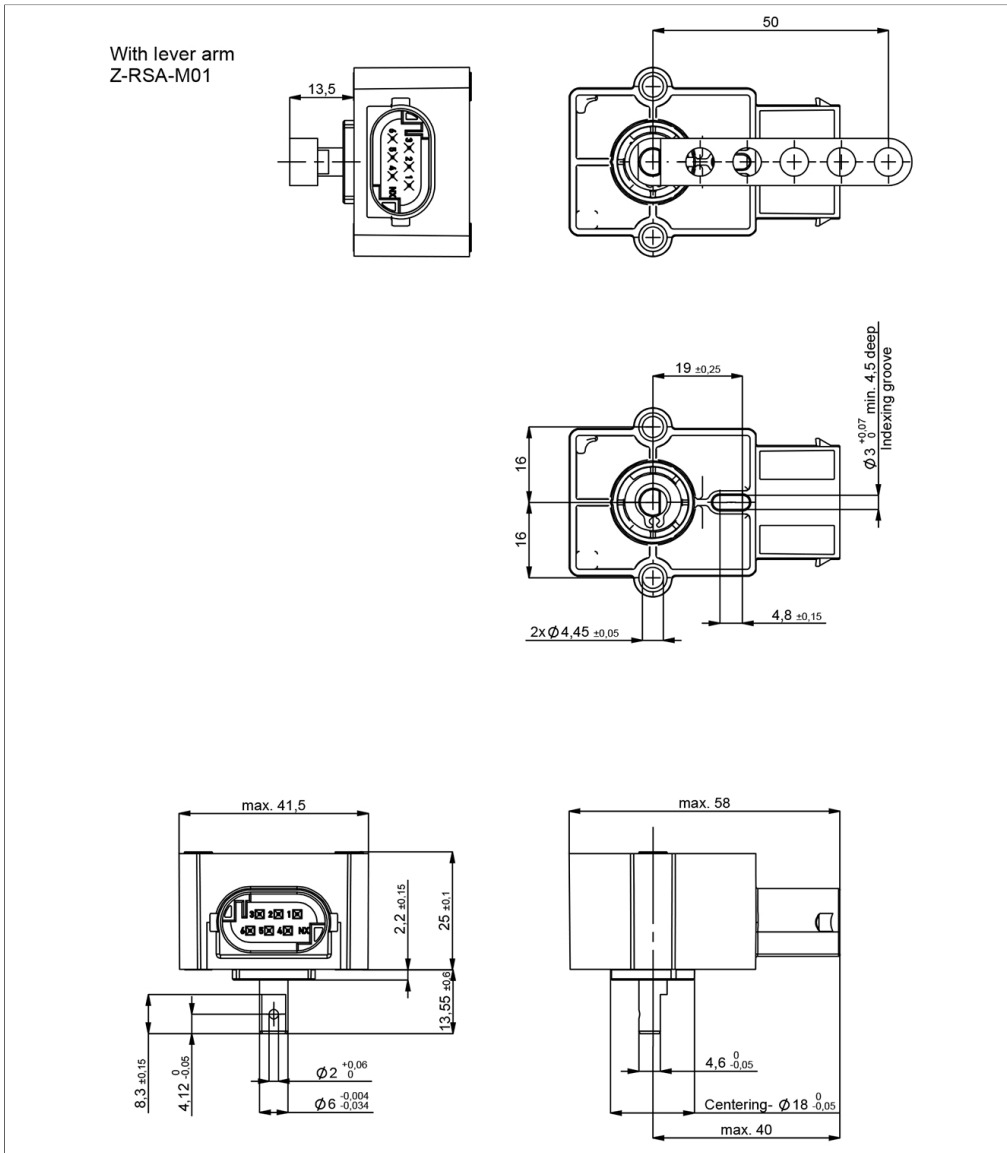

Output characteristic A
(standard)
RSA-3201/3202:
When the flattening of the shaft
or the lever arm points towards
the connector, the sensor is near
the electrical center position.

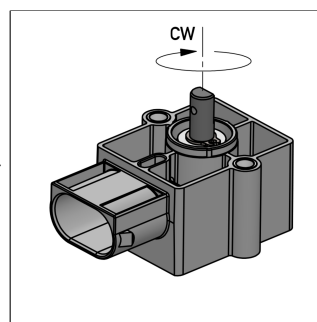

Output characteristic B
(180° offset)
RSA-3221/3222:
When the flattening of the shaft
or the lever arm is
located opposite to the
connector, the sensor is near
the electrical center position.

Technical Data

Type	RSA-32_...-32_-521
Output signal	4 ... 20 mA
Burden	@Ub > 13 V: ≤ 500 Ω, @Ub ≤ 13 V: ≤ 250 Ω
Number of channels	1 / 2
Diagnosis	activated (in case of error, output signal is outside of the plausible signal range)
Update rate	typ. 3.4 kHz
Measuring range	0 ... 30° up to 0 ... 360° in 10°-steps
Absolute linearity at measuring range	360°: ≤ ±0.4 %FS, 240°: ≤ ±0.45 %FS, 180°: ≤ ±0.5 %FS, 120°: ≤ ±0.55 %FS, 60°: ≤ ±0.8 %FS, 30°: ≤ ±1.25 %FS
Resolution	12 bits
Repeatability	typ. ≤ ±0.1°
Hysteresis	typ. < ±0.1° Only measuring range 360°: typ. < 0.25° (lower hysteresis on request)
Temperature error	Measuring range < 180°: typ. ±1.2 %FS, Measuring range ≥ 180°: typ. ±0.6 %FS
Supply voltage Ub	12/24 VDC (8 ... 34 VDC)
Current consumption w/o load	typ. 12 mA per channel
Overvoltage protection	60 VDC (10 min.)
Polarity protection	yes (supply lines and outputs)
Short circuit protection	yes (vs. GND and supply voltage)
Insulation resistance (500 VDC)	≥ 10 MΩ
Environmental Data	
Max. operational speed	120 rpm (temporary 800 rpm)
Vibration IEC 60068-2-6	20 g, 5 ... 2000 Hz, Amax = 0.75 mm
Shock IEC 60068-2-27	50 g, 6 ms
Protection class ISO 20653	IP67 (shaft side), IP69K (housing incl. electronics)
Operating temperature	-40 ... +105°C* * The max. operating temperature depends on supply voltage Ub and burden (see temp.diagram)
Operating humidity	0 ... 98 % R.H. (no condensation)
Life	typ. 30 Mio. movements (when operated without lever)
Functional safety	Suitable for safety-related applications according to ISO 13849 after customer validation. Further safety data (DCavg...) and support for functional safety are available on request.
MTTF (IEC 60050)	726 years (one-channel), 448 years (partly redundant, per channel) or 364 years (fully redundant, per channel)
MTTFd (EN ISO 13849-1 parts count method, w/o load)	1453 years (one-channel), 896 years (partly redundant, per channel) or 727 years (fully redundant, per channel)
MTTFd-certificate	https://www.novotechnik.de/en/downloads/certificates/mttf-d-certificates/
Traceability	Serial number on type labeling: production batch of the sensor assembly and relevant sensor components
EMC Compatibility	
ISO 10605 ESD (Handling/Component)	8 kV / 15 kV
ISO 11452-2 Radiated HF-fields	100 V/m
ISO 11452-5 Radiated HF-Fields, stripline	200 V/m
CISPR 25 Radiated emission	Level 5
ISO 7637-2 Transient Emissions	Level 3
ISO 7637-2 Pulses on supply lines	(1, 2a, 2b, 3a, 3b, 4, 5) Level 4
ISO 7637-3 Pulses on output lines	Level 4
EN 13309 Construction machinery	
Emission/Immunity E1	acc. to ECE-R10
ISO 13766-1/-2 Construction machinery	Any dual-channel version

FS = Full scale: Signal span according to electrical measuring range

Connection Assignment

	Single-channel	Partly redundant	Fully redundant
Supply voltage Ub 1	Pin 1	Pin 1	Pin 1
GND 1	Pin 2	Pin 2	Pin 2
Signal output 1	Pin 4	Pin 4	Pin 4
Signal output 2	-	Pin 3	Pin 3
Supply voltage Ub 2	-	-	Pin 6
GND 2	-	-	Pin 5
Not assigned	Pin 3, Pin 5, Pin 6	Pin 5, Pin 6	-

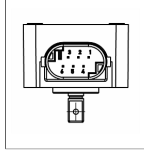
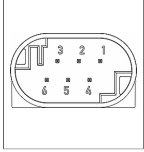

**Technical Data
Output
Characteristics**

Temperature Diagram

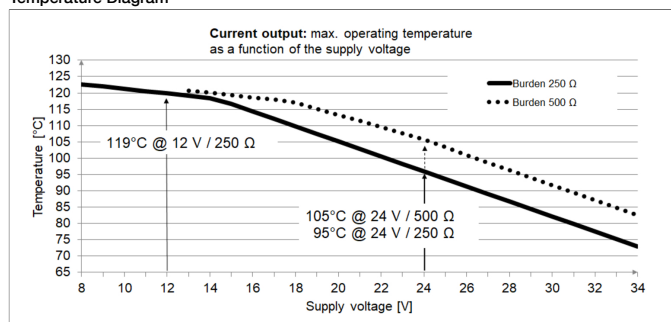

Output characteristic

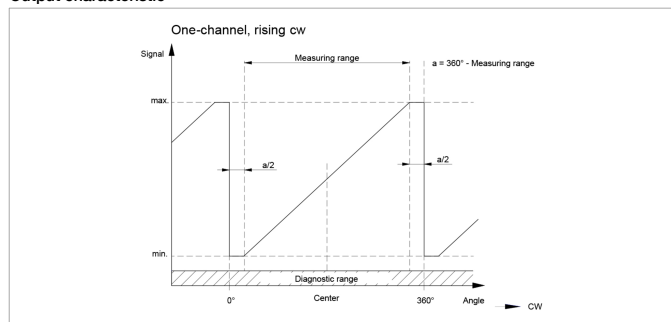

Output characteristic

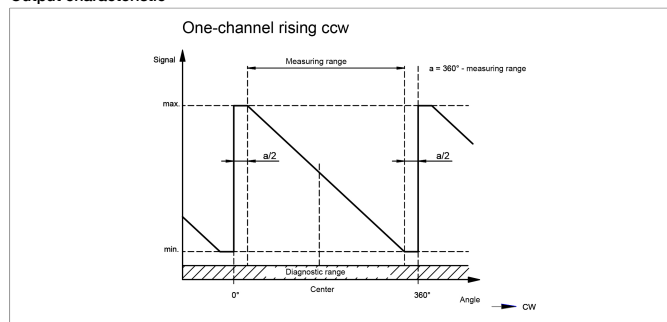

Output characteristic

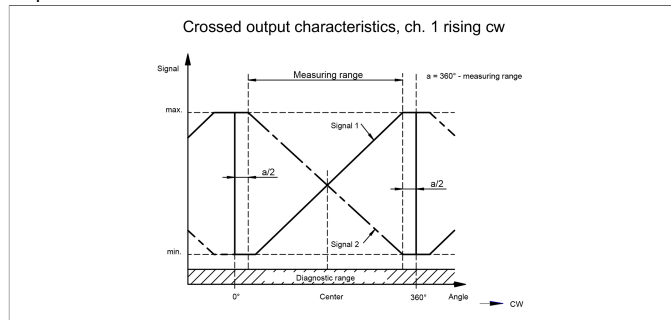

Output characteristic

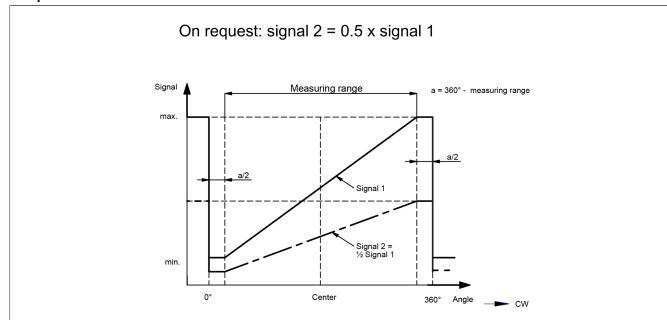

Output characteristic

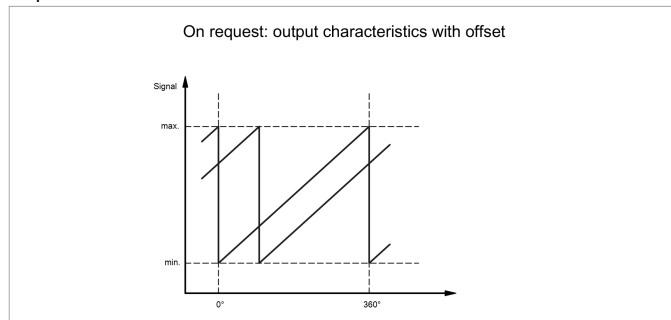

Output characteristic

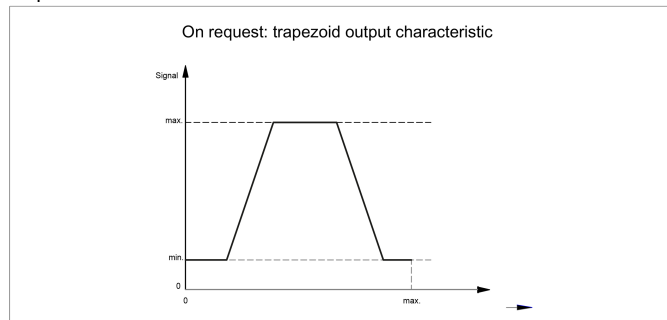

Sensor Mounting

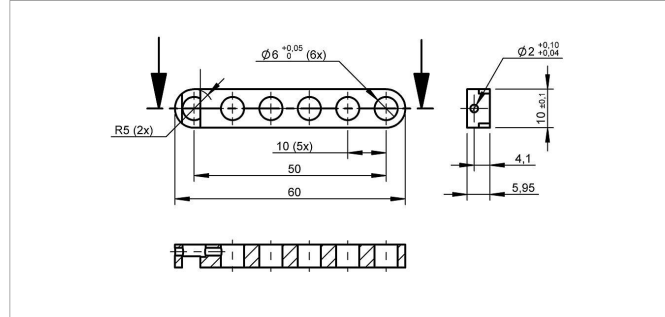
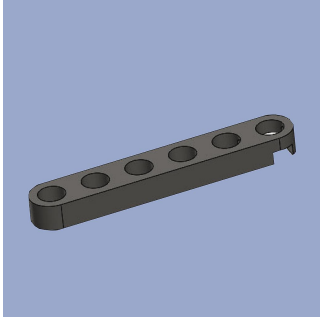

Z-RSA-M01

Lever arm 50 mm for mounting at shaft with locking pin (included in delivery).

Further levers (geometry, materials...) on request.

Material Aluminium, anodized

P/N **Type**

400105062 Z-RSA-M01

Connector System MQS

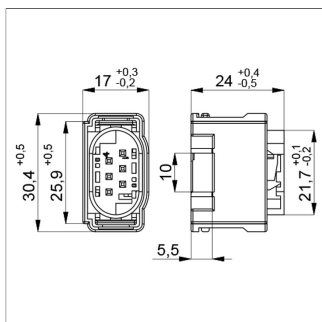

EEM-33-34

Connector kit MQS System including

- 1 plug socket (female), PBT GF15, AMP P/N 1-967616-1
- 6 tinned contacts for cable cross-section area 0.25 ... 0.35 mm² (AWG 22), AMP-P/N 963727-1 or 5-962885-1
- 6 single conductor sealings AMP P/N 967067-2

Operating temp. -40 ... +120°C

P/N	Type
400005666	EEM-33-34

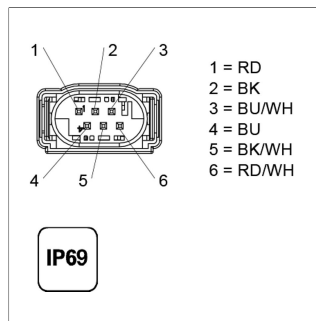
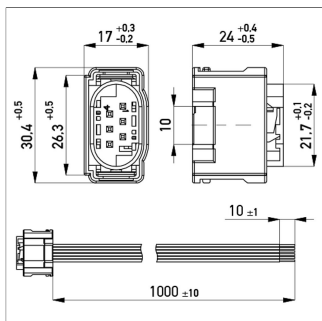
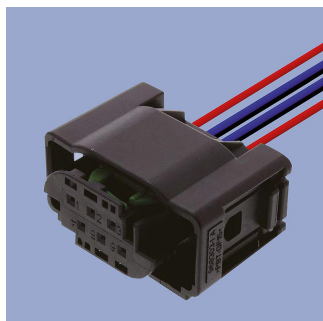

EEM-33-24

Connector MQS AMP P/N 1-967616-1, 6-pin, PBT GF15, with lead wires 0.5 mm², PVC, 1 m, open ended

Operating temp. -40 ... +120°C

Lead wires PVC, 6x0.5 mm²

P/N	Type	Length
400108029	EEM-33-24	1 m

Novotechnik U.S., Inc.
155 Northboro Road

Southborough, MA 01772
Phone 508 485 2244
Fax 508 485 2430
info@novotechnik.com
www.novotechnik.com



© Mar 2, 2022

The specifications contained in our datasheets are intended solely for informational purposes. The documented specification values are based on ideal operational and environmental conditions and can vary significantly depending on the actual customer application. Using our products at or close to one or more of the specified performance ranges can lead to limitations regarding other performance parameters. It is therefore necessary that the end user verifies relevant performance parameters in the intended application. We reserve the right to change product specifications without notice.